

LIGHT DETECTOR

(NON INVERTING COMPARATOR)

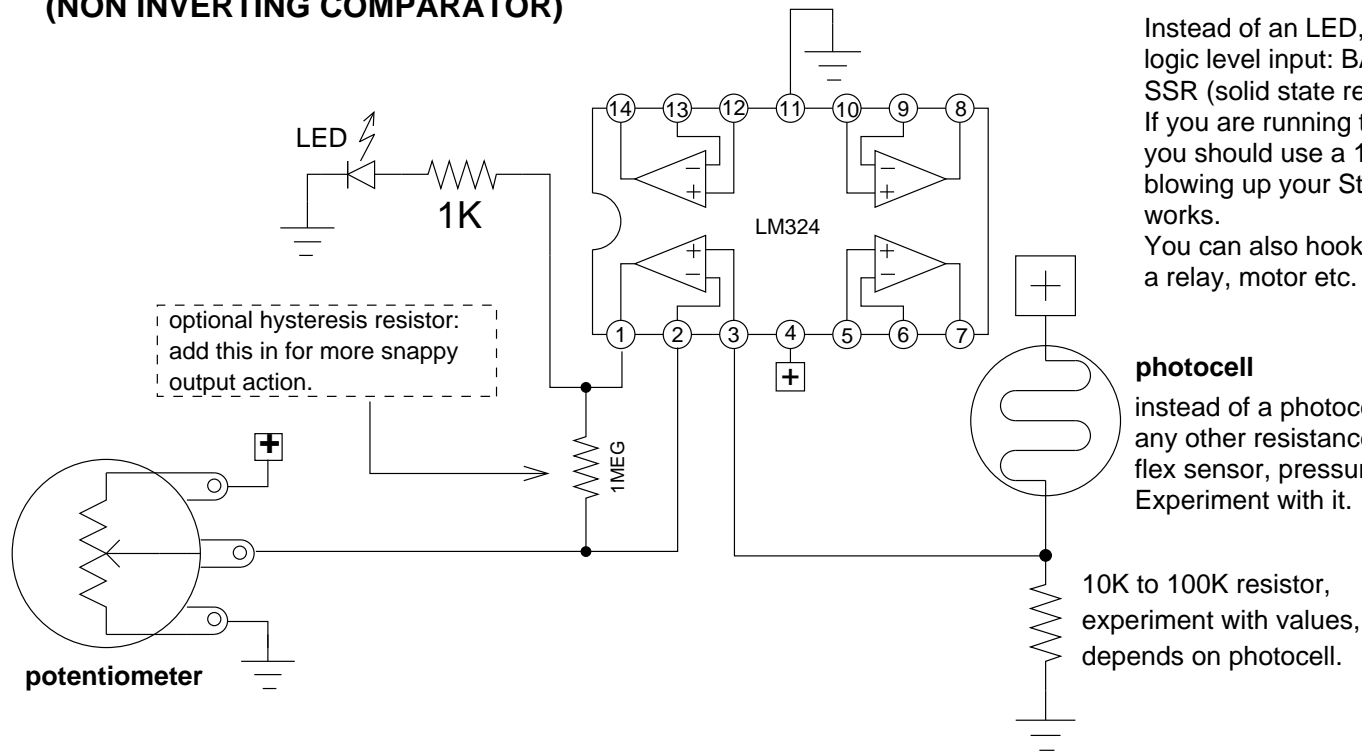

Instead of an LED, you can hook pin 6 up to any logic level input: BASIC stamp, another chip, SSR (solid state relay).

If you are running the circuit at higher than 5 volts, you should use a 1K to 2.2K series resistor to avoid blowing up your Stamp input. Use the highest value that works.

You can also hook up pin 6 to a transistor to turn on a relay, motor etc.

photocell

instead of a photocell, you can use any other resistance based sensor: flex sensor, pressure sensor etc. Experiment with it.

10K to 100K resistor, experiment with values, depends on photocell.

Use the pot to tune the trip point (sensitivity) as follows:

1. Set it up so the light you want to detect is shining on the photocell.
2. Turn the pot back and forth: one direction or the other will make the LED turn off and stay off, no matter what you do to the photocell. Turn the pot fully in this direction.
3. Now turn the pot SLOWLY back in the other direction, until the LED just turns on: you've found the trip point.
4. Give it a little bit of an extra turn in this direction. Now you should be able to easily turn the LED off and on by blocking the light source.
5. You can play around with the pot LOTS to get different sensitivities, adjust for different ambient light etc.
6. If you get confused, start all over from step 1.

IN THIS CIRCUIT AN LED TURNS ON WHEN IT IS BRIGHT OUT. THIS IS A NON-INVERTING COMPARATOR. TO MAKE A DARK DETECTOR SWAP PINS 2 AND 3. THIS IS AN INVERTING COMPARATOR. REMEMBER TO GROUND UNUSED INPUTS!